

TRIANGULAR

SEPARADOR HIDRAÚLICO

CALEFFI



Triangular S.A. en la constante acción de mejoramiento de sus productos, se reserva la posibilidad de modificar los datos indicados en esta documentación en cualquier momento y sin previo aviso. El presente es un documento informativo y no puede ser considerado un contrato hacia terceros.

triangular.com.ar

TRIANGULAR



2,5 m³ / h

Código X548006

Modelo 548006



Epoxi
Pintura



Acero
Cuerpo



10 Bar
Agua



Pe-X
Aislación Térmica



Max 100°C
Min 0°C



30 %
Anti Congelante



20.000 kCal/h
Piso radiante



25.000 kCal/h
Radiadores

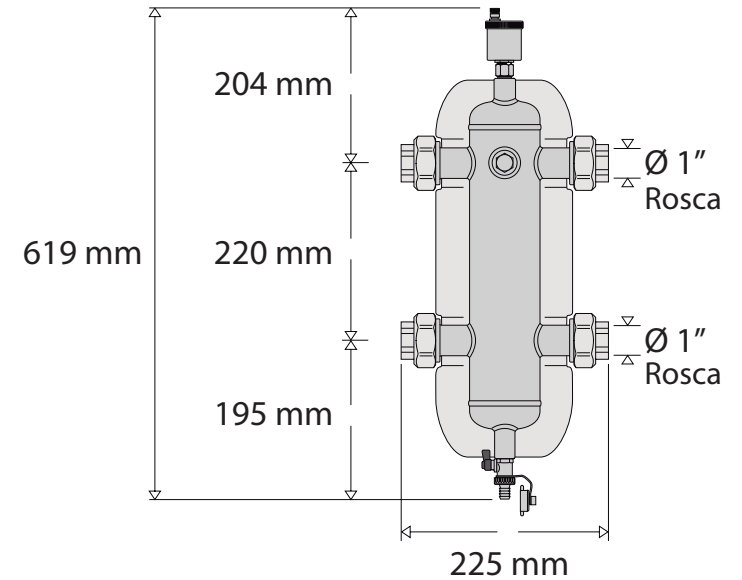

5 Kg
Peso



Alto
510 mm

Ancho
270 mm

Prof.
170 mm

TRIANGULAR



4 m³ / h

Código X548007

Modelo 548007



Epoxi
Pintura



Acero
Cuerpo



10 Bar
Agua



Pe-X
Aislación Térmica



Max 100°C
Min 0°C



30 %
Anti Congelante



32.000 kCal/h
Piso radiante



40.000 kCal/h
Radiadores

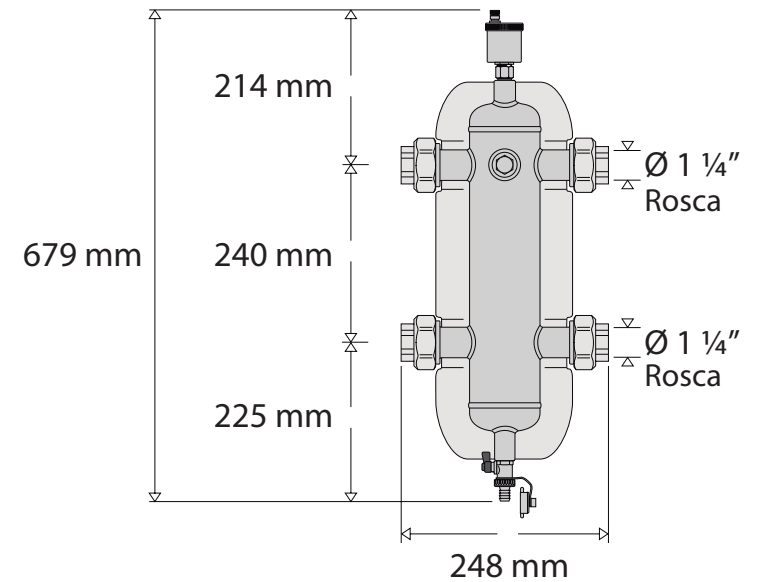

6,2 Kg
Peso



Alto
560 mm

Ancho
280 mm

Prof.
200 mm

TRIANGULAR



6 m³ / h

Código X548008

Modelo 548008



Epoxi
Pintura



Acero
Cuerpo



10 Bar
Agua



Pe-X
Aislación Térmica



Max 100°C
Min 0°C



30 %
Anti Congelante



48.000 kCal/h
Piso radiante



60.000 kCal/h
Radiadores

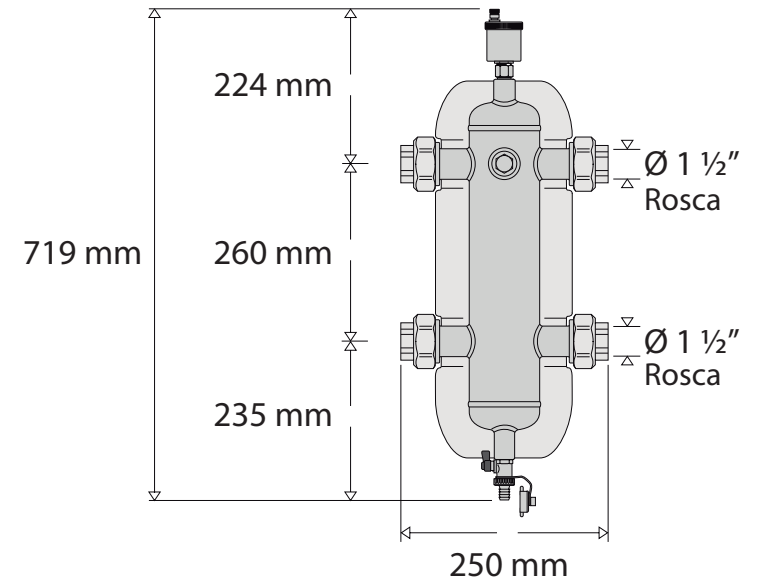

7,5 Kg
Peso



Alto
570 mm

Ancho
300 mm

Prof.
180 mm

TRIANGULAR



8,5 m³ / h

Código X548009

Modelo 548009



Epoxi
Pintura



Acero
Cuerpo



10 Bar
Agua



Pe-X
Aislación Térmica



Max 100°C
Min 0°C



30 %
Anti Congelante



68.000 kCal/h
Piso radiante



85.000 kCal/h
Radiadores

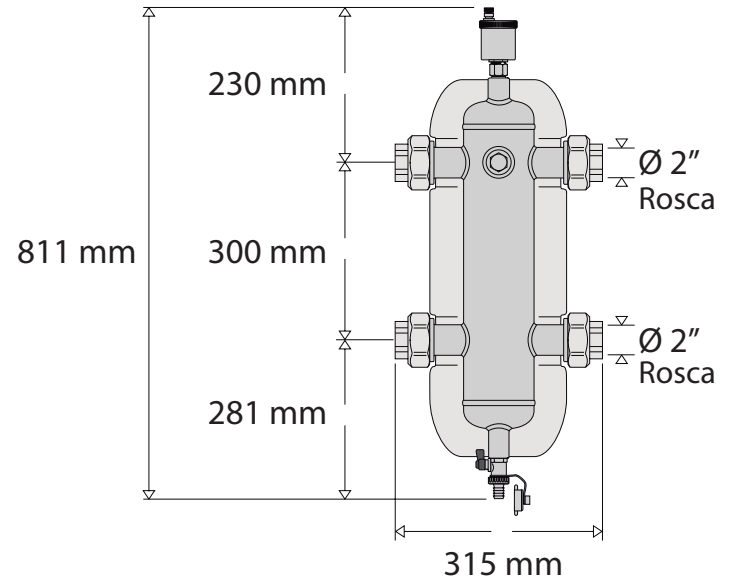

14,2 Kg
Peso



Alto
760 mm

Ancho
375 mm

Prof.
235 mm

TRIANGULAR



9 m³ / h

Código X548052

Modelo 548052



Epoxi
Pintura



Acero
Cuerpo



10 Bar
Agua



Poliuretano
Aislación Térmica



Max 100°C
Min 0°C



50 %
Anti Congelante



72.000 kCal/h
Piso radiante



90.000 kCal/h
Radiadores

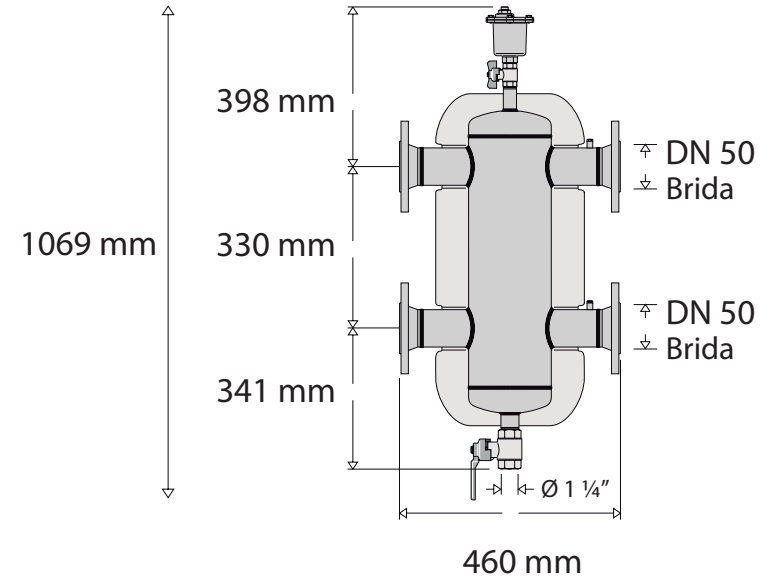

34,5 Kg
Peso



Alto 1050 mm
Ancho 490 mm
Prof. 410 mm

TRIANGULAR



18 m³ / h

Código X548052

Modelo 548052



Epoxi
Pintura



Acero
Cuerpo



10 Bar
Agua



Poliuretano
Aislación Térmica



Max 100°C
Min 0°C



50 %
Anti Congelante



144.000 kCal/h
Piso radiante



180.000 kCal/h
Radiadores

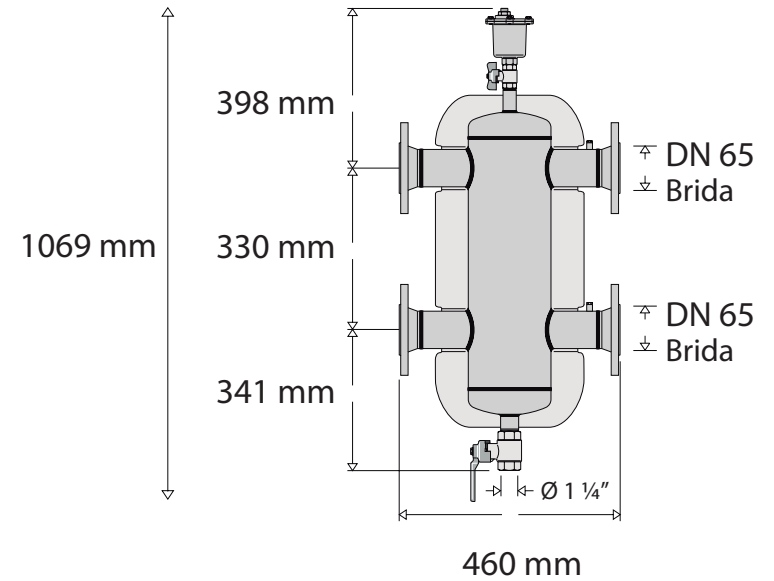

38 Kg
Peso



Alto 1050 mm
Ancho 490 mm
Prof. 420 mm

TRIANGULAR



28 m³ / h

Código X548082

Modelo 548082



Epoxi
Pintura



Acero
Cuerpo



10 Bar
Agua



Poliuretano
Aislación Térmica



Max 100°C
Min 0°C



50 %
Anti Congelante



224.000 kCal/h
Piso radiante



280.000 kCal/h
Radiadores

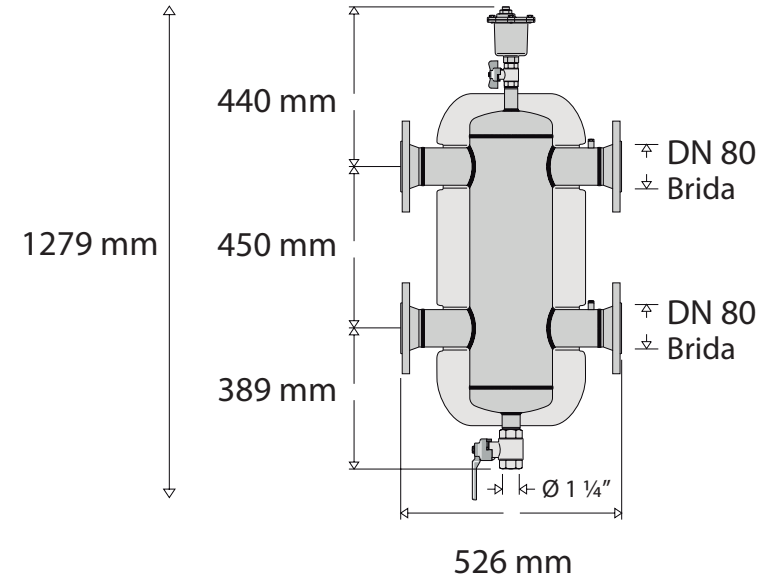

51 Kg
Peso



Alto 1050 mm
Ancho 560 mm
Prof. 420 mm

TRIANGULAR



56 m³ / h

Código X548102

Modelo 548102



Epoxi
Pintura



Acero
Cuerpo



10 Bar
Agua



Poliuretano
Aislación Térmica



Max 100°C
Min 0°C



50 %
Anti Congelante



448.000 kCal/h
Piso radiante



560.000 kCal/h
Radiadores

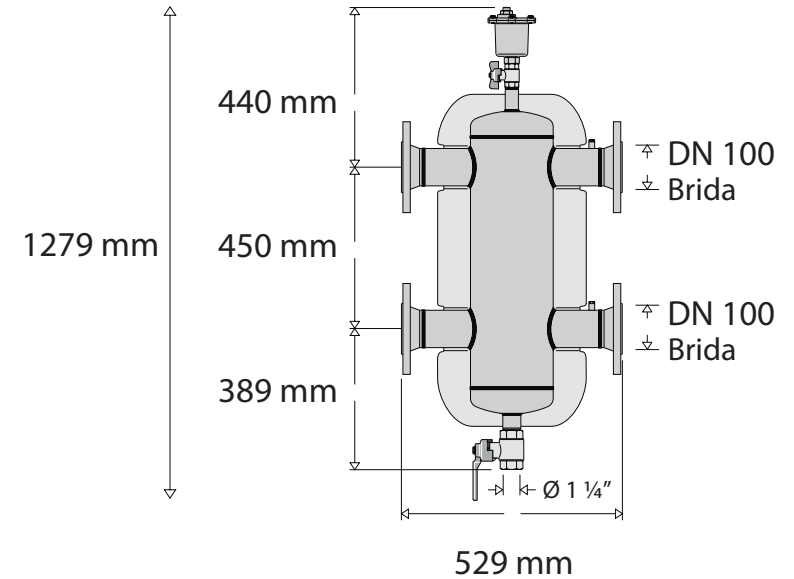

55 Kg
Peso



Alto
1050 mm

Ancho
560 mm

Prof.
420 mm

TRIANGULAR



180 m³ / h

Código X548200

Modelo 548200



Epoxi
Pintura



Acero
Cuerpo



10 Bar
Agua



Max 100°C
Min 0°C



1.440.000 kCal/h
Piso radiante



1.800.000 kCal/h
Radiadores



50 %
Anti Congelante

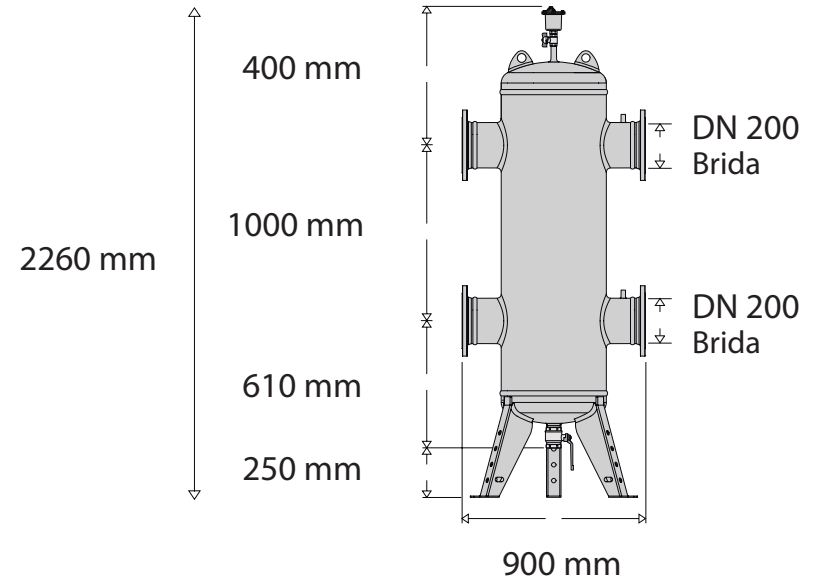

255 Kg
Peso



Alto
2100 mm

Ancho
1000 mm

Prof.
500 mm



**Separador Hidráulico
Caleffi**



Piso radiante



Radiadores

2,5 m ³ / h	20.000	kCal / h	25.000	kCal / h
4 m ³ / h	32.000	kCal / h	40.000	kCal / h
6 m ³ / h	48.000	kCal / h	60.000	kCal / h
8,5 m ³ / h	68.000	kCal / h	85.000	kCal / h
9 m ³ / h	72.000	kCal / h	90.000	kCal / h
18 m ³ / h	144.000	kCal / h	180.000	kCal / h
28 m ³ / h	224.000	kCal / h	280.000	kCal / h
56 m ³ / h	448.000	kCal / h	560.000	kCal / h
180 m ³ / h	1.440.000	kCal / h	1.800.000	kCal / h

TRIANGULAR

Líder en Calefacción & Agua Caliente